

3M 4496 VHB TAPE

Foam Tape Installation Instructions



SOELBERG | INDUSTRIES

What is needed for installation:

VHB foam tape (3M 4496)



J-roller



4 easy to follow steps:

1 Use a cloth to wipe away dust and debris from the back of each panel and substrate.

2 Attach strips of tape to the back of each panel by pulling off the protective paper. (see recommended quantity)

3 Use a j-roller to ensure the tape is sealed well before removing the protective paper from the back side.

4 Applying pressure, attach the panel to the substrate.

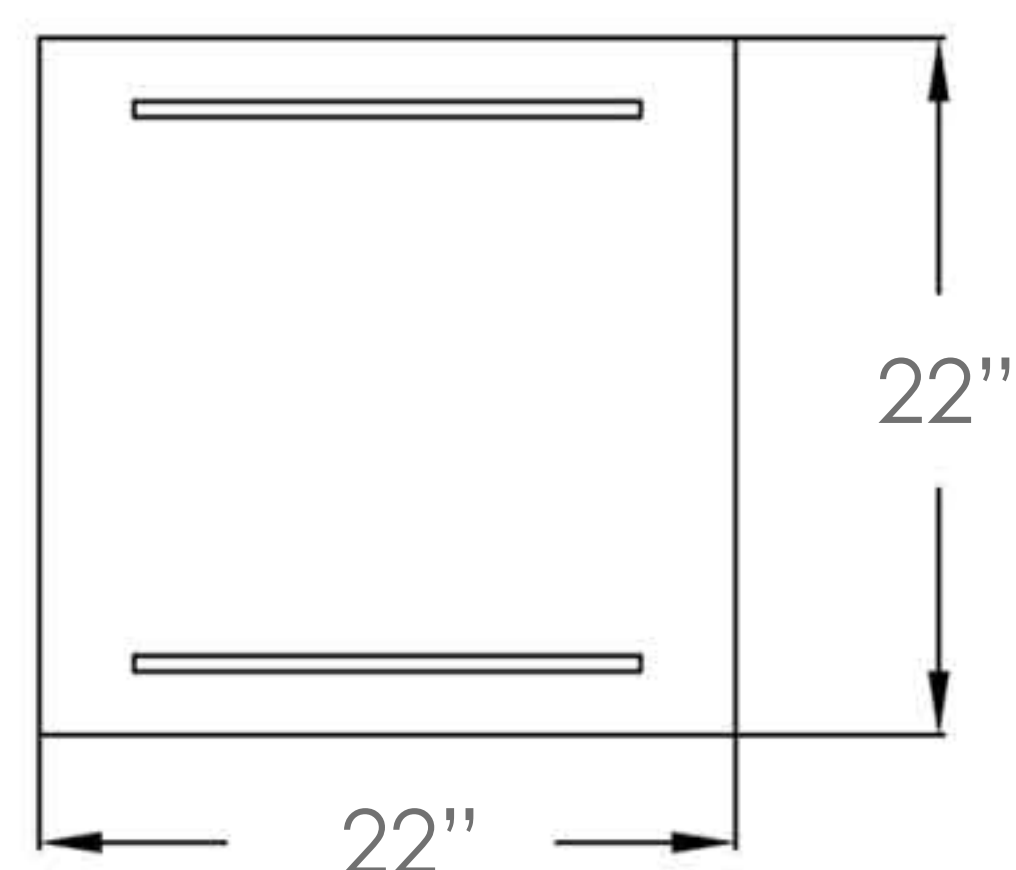

Geo Tiles
(Small roll of VHB tape, 88 inches, for every two tiles. Attach to the top and bottom of each panel. Depending upon site conditions, more tape may be necessary.)

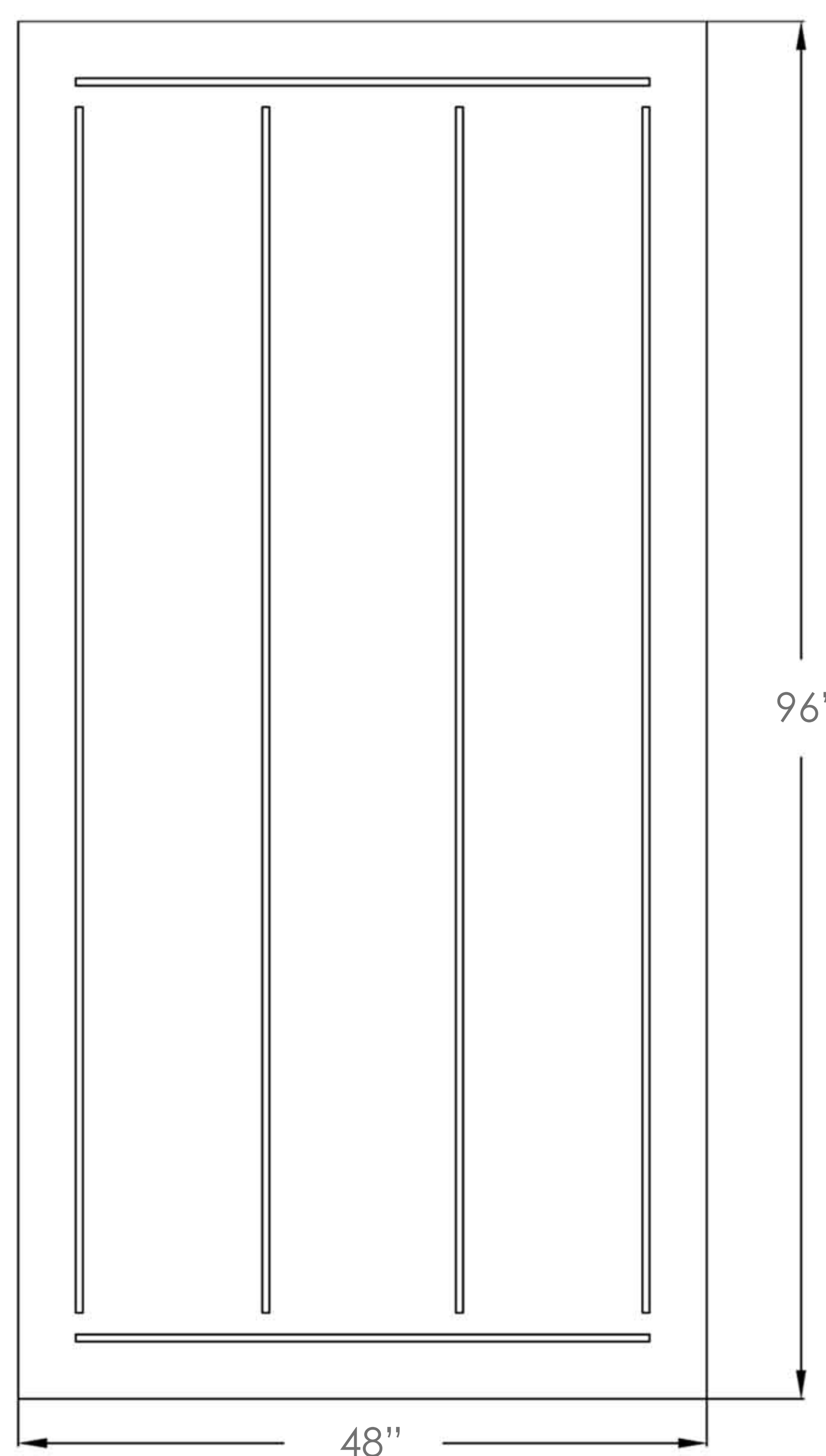

Full Panel
(Attach tape around the perimeter approximately 12 inches apart running the length of each side of the panel. Depending upon site conditions, more tape may be necessary.)

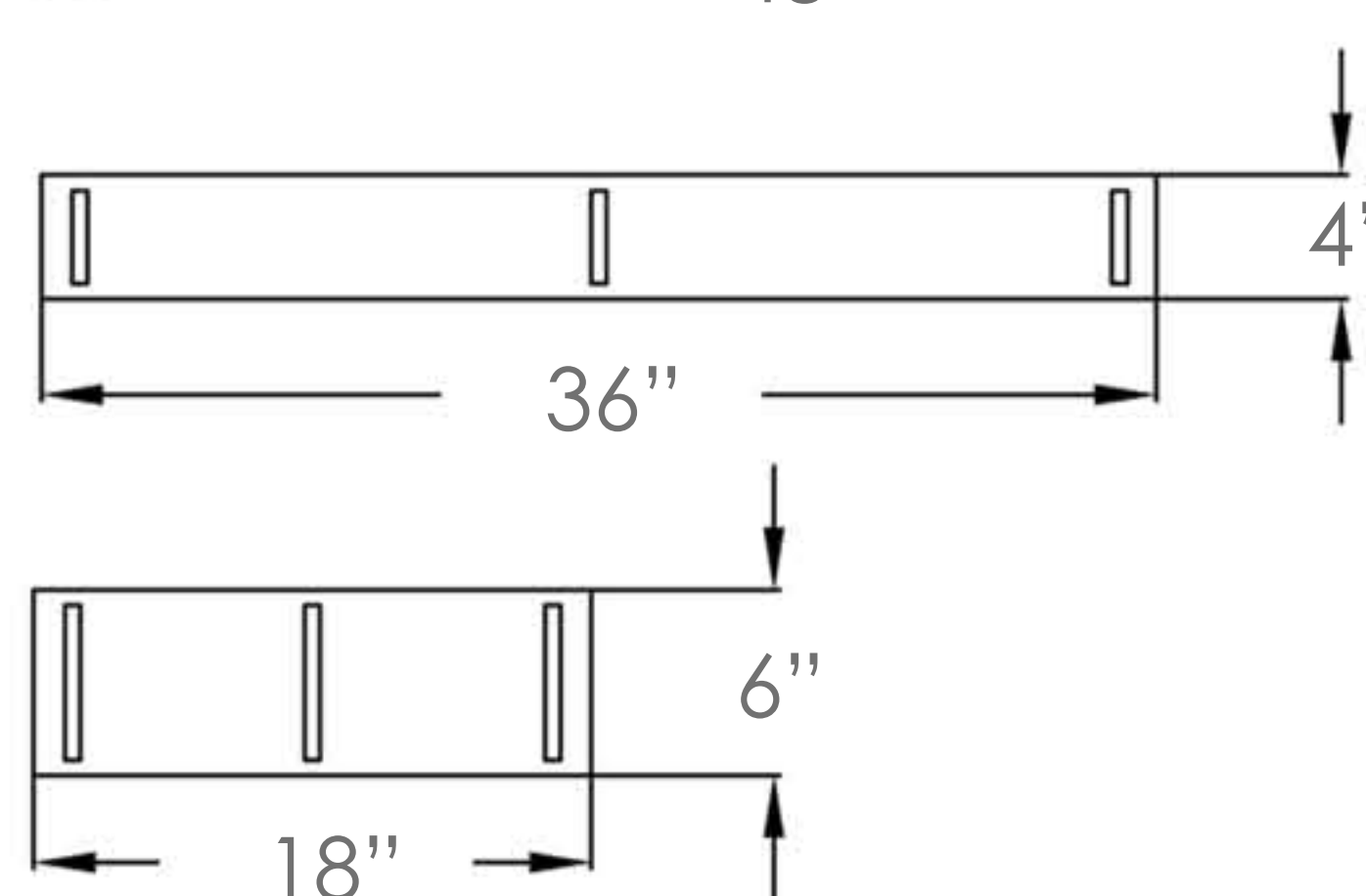

Piastra
(50 feet of VHB tape for every 32 square feet of product. Depending upon site conditions, more tape may be necessary.)

Note: not all walls are plumb, square nor flat. Modifications may be necessary. It is your responsibility to determine the best installation method for your project based upon site conditions. For additional strength and support, use industrial adhesive together with VHB tape. It is the sole responsibility of the installer to meet all building codes.